

## SERVICE MANUAL

English

No. 1305

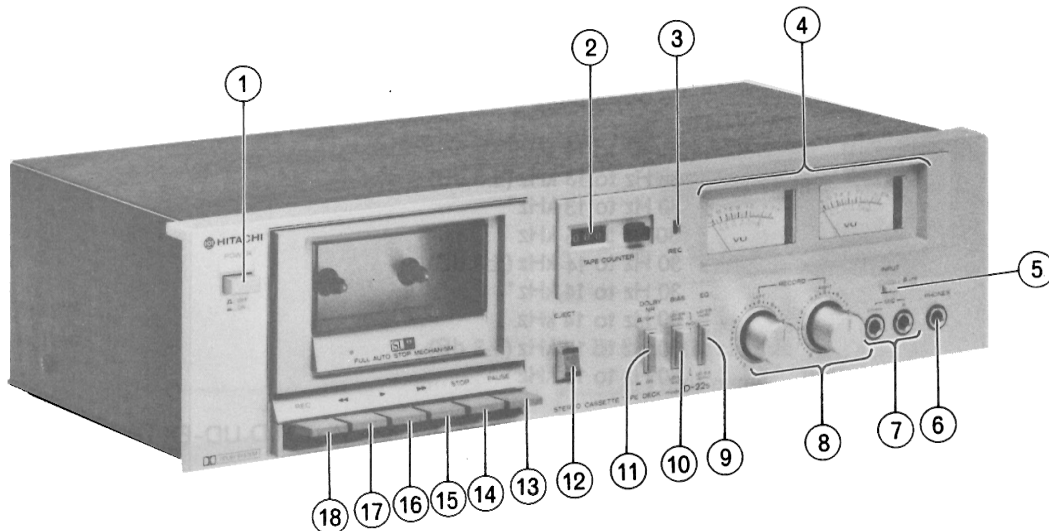

### KEY TO ILLUSTRATIONS

- |                                  |                             |
|----------------------------------|-----------------------------|
| ① POWER (MAINS) SWITCH           | ⑩ TAPE SELECT SWITCH (BIAS) |
| ② TAPE COUNTER                   | ⑪ DOLBY NR SWITCH           |
| ③ RECORD INDICATOR               | ⑫ EJECT BUTTON              |
| ④ VU METERS                      | ⑬ PAUSE BUTTON              |
| ⑤ INPUT SELECTOR                 | ⑭ STOP BUTTON               |
| ⑥ HEADPHONE JACK                 | ⑮ FAST FORWARD BUTTON       |
| ⑦ MICROPHONE JACKS               | ⑯ PLAYBACK BUTTON           |
| ⑧ RECORDING LEVEL CONTROLS       | ⑰ REWIND BUTTON             |
| ⑨ TAPE SELECT SWITCH (EQUALIZER) | ⑱ RECORD BUTTON             |

### SAFETY PRECAUTION

The following precautions should be observed when servicing.

1. Since many parts in the unit have special safety related characteristics, always use genuine Hitachi's replacement parts. Especially critical parts in the power circuit block should not be replaced with other makes.

Critical parts are marked with  $\Delta$  in the schematic diagram and circuit board diagram.

2. Before returning a repaired unit to the customer, the service technician must thoroughly test the unit to ascertain that it is completely safe to operate without danger of electrical shock.

#### Note :

U ..... USA  
BS ..... Great Britain

FS ..... Switzerland and Scandinavia  
AU ..... Australia

C ..... Canada  
W ..... General Area

## STEREO CASSETTE TAPE DECK

## SPECIFICATIONS

<b>Semi-conductors :</b>	
IC's	3
Transistors	7 (For U, C) 8 (For BS, FS, AU, W)
Diodes	15 (For U, C) 18 (For BS, FS, AU, W)
LED	1
<b>Track System :</b>	4 track 2 channel
<b>Tape :</b>	Cassette tape (C-30, 60, 90)
<b>Tape Speed :</b>	4.75 cm/s
<b>Recording System and Bias Frequency :</b>	AC bias, 85 kHz
<b>Erasing System :</b>	AC erase
<b>Erase Ratio :</b>	65 dB or more (at 1 kHz)
<b>Frequency Response :</b>	
UD-ER (Normal)	30 Hz to 14 kHz 30 Hz to 13 kHz ( $\pm 3$ dB) 30 Hz to 13 kHz*
UD-EX (CrO <sub>2</sub> )	30 Hz to 15 kHz 30 Hz to 14 kHz ( $\pm 3$ dB) 30 Hz to 14 kHz*
FeCr	30 Hz to 14 kHz 30 Hz to 13 kHz ( $\pm 3$ dB) 30 Hz to 13 kHz*
<b>S/N (Signal to Noise Ratio) :</b>	
Dolby NR OFF	56 dB (A weighted, Reference 3% T.H.D. UD-EX Tape) 56 dB*
Dolby NR ON	64 dB (A weighted, Reference 3% T.H.D. UD-EX Tape) 63 dB*
<b>Wow and Flutter :</b>	0.08% (WRMS) 0.20%*
<b>Input Sensitivity and Impedance :</b>	
Microphone	0.35mV, 300 ohms to 5 kohms
Line in	60mV, 50 kohms or more
DIN (Record/Playback)	0.35mV, 3.3 kohms (For BS, FS, AU, W) 500mV
<b>Output Level :</b>	
<b>Output Load Impedance :</b>	
Line out	50 kohms or more
DIN (Record/Playback)	50 kohms or more (For BS, FS, AU, W)
Headphone	8 ohms to 2 kohms
<b>Distortion :</b>	1.5% (1 kHz, 0VU)
<b>Cross Talk :</b>	
Between tracks	60 dB or more (at 1 kHz)
Between channels	30 dB or more (at 1 kHz)
<b>Power Supply :</b>	AC 220V, 50 Hz (For FS) AC 120V, 60 Hz (For U, C) AC 240V, 50 Hz (For BS, AU) AC 100 to 110V/115 to 127V/200 to 220V/230 to 250V, 50/60 Hz (For W)
<b>Power Consumption :</b>	8W (For U, C, FS), 9W (For BS, AU, W)
<b>Dimensions :</b>	110(H)×435(W)×193(D)mm
<b>Weight :</b>	3.4 kg
<b>Motor :</b>	Electronically controlled DC motor
<b>Heads :</b>	Record/Playback head×1 Erase head×1

\* According to DIN 45 500

Specifications and Schematic diagram are subject to change for performance improvement without notice.

# DISASSEMBLY

## 1. Cassette lid

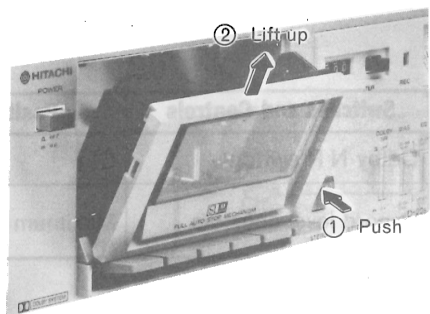

## 4. Meter PC board

- 1) Top cover (See item 2)
- 2) 4 stoppers

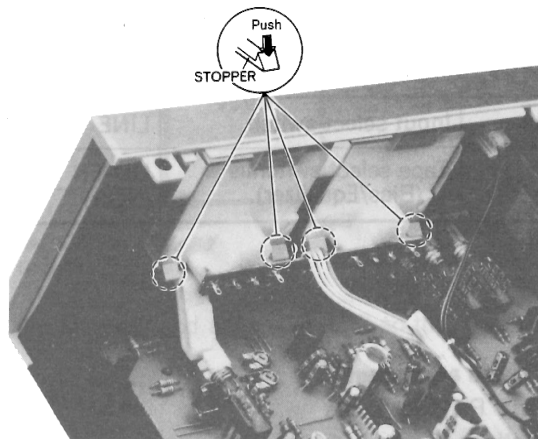

## 2. Top cover

- 1) (1-1) 1 screw
- 2) (1-2) 1 screw

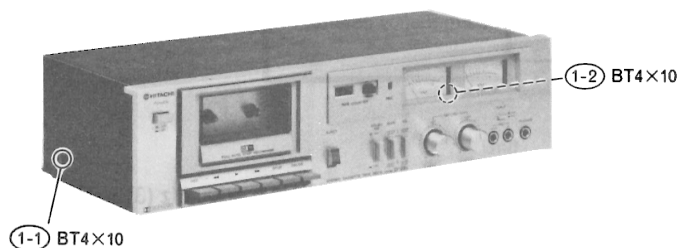

## 5. Cassette chassis

- 1) Front panel
  - 2) (3) 2 screws
- (See item 3)

## 6. Main PC board

- 1) Cassette chassis (See item 5)
  - 2) (4) 1 screw
  - 3) 2 stopper
  - 4) (5) 1 screw
- (See item 3)

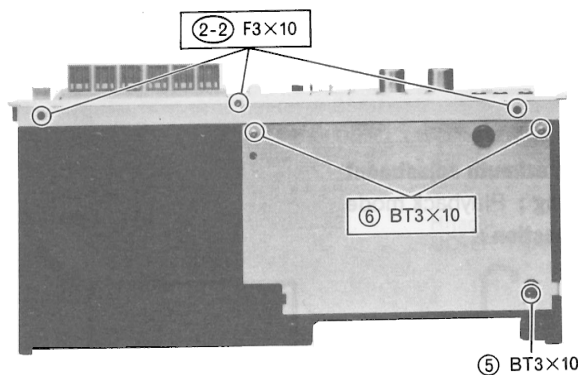

## 3. Front panel

- 1) Cassette lid (See item 1)
- 2) Top cover (See item 2)
- 3) (2-1) 4 screws
- 4) (2-2) 3 screws (See item 6)
- 5) 2 Knobs

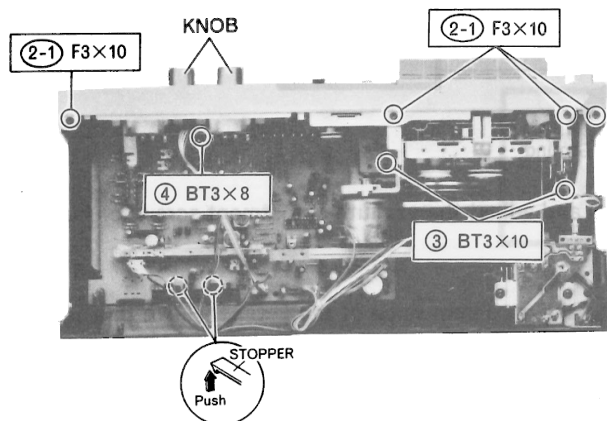

## 7. Bottom cover

- 1) (1-2) 1 screw (See item 2)
  - 2) (5) 1 screw
  - 3) (6) 2 screws
- (See item 6)

## ADJUSTMENT

Perform the following adjustments in the sequence stated after cleaning the head, pressure roller, and capstan with a head cleaning stick moistened in alcohol. Also, unless specially indicated otherwise, set the switches and controls to the positions indicated in the table.

Symbol No.	Switches and Controls	Position	Symbol No.	Switches and Controls	Position
S3	Input select switch	LINE	S6	Dolby N R switch	OFF
S4, S5	Tape select switches (Bias/Equalizer)	UD-ER (NOR)	RV1L, R	Record level controls	Maximum

### 1. Tape speed adjustment

**Setting :** Playback mode

**Connection :**

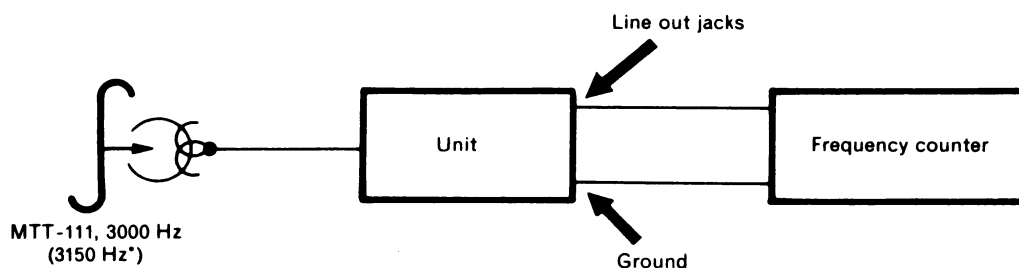

**Adjustment :** Warm up the unit for approximately 20 minutes ; then playback test tape MTT-111, 3000 Hz (3150 Hz\*) and measure the speed deviation with a frequency counter. If required, adjust the semi-variable resistor on the motor for a reading of  $3000 \text{ Hz} \pm_{-10}^{+30} \text{ Hz}$  (3150 Hz\*). Carry out the measurement at the middle of the tape.

\* According to DIN 45 500.

### 2. Head azimuth adjustment

**Setting :** Playback mode

**Connection :**

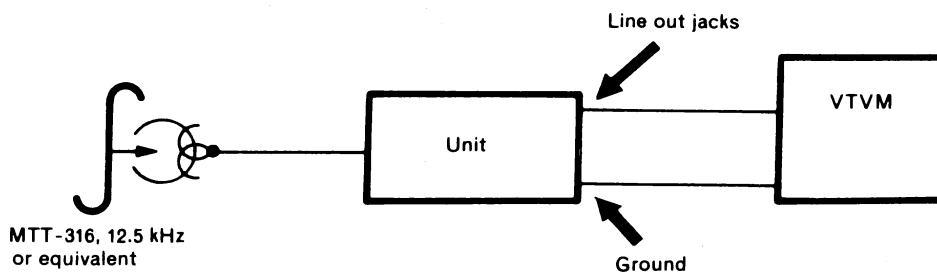

**Adjustment :** Playback a test tape (MTT-316, 12.5 kHz or equivalent) and adjust the azimuth adjustment screw for maximum output.

**Note :**

When the maximum values of both channels are different, tune to the maximum value of the L channel. In this case, the difference between the maximum values of both channels should be 2 dB or less.



**3. Playback output and VU meter adjustment**

**Setting :** Playback mode

**Connection :**

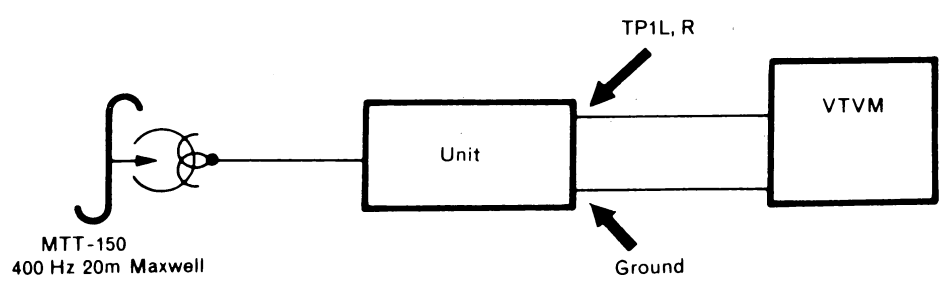

**Adjustment :** Playback a Dolby calibration tape (MTT-150, 400 Hz 20m Maxwell) and adjust RT1L, R so that the voltage of TP1L, R becomes 0.775V.

Then, adjust RT3 so that the meter indicators deflect to the Dolby marks (   $\pm 1.5$  VU).

**4. Bias current adjustment**

**Setting :** Recording mode

**Connection :**

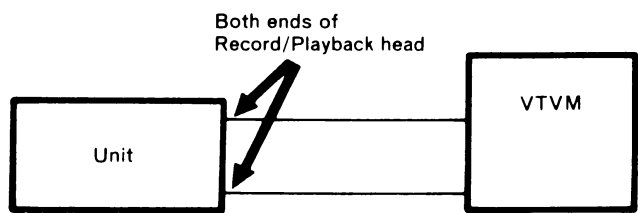

**Adjustment :** Set the record mode. Adjust RT4L, R so that the bias voltage of 15V is applied to the both ends of Record/Playback head.

**5. Record/playback output level, frequency characteristics adjustment**

**Setting :** Recording/playback mode

**Connection :**

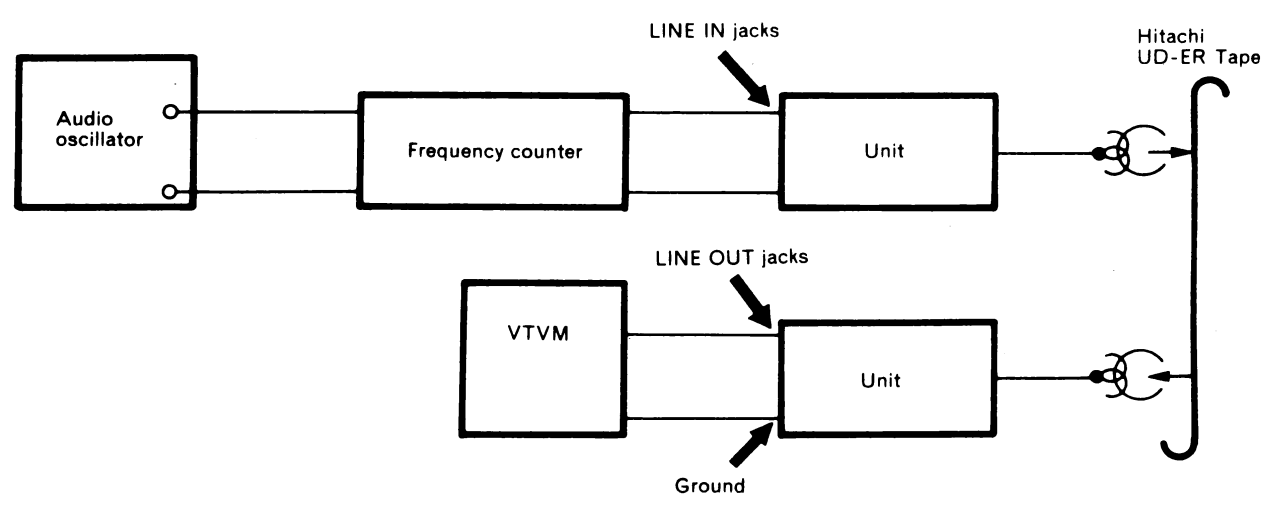

**Adjustment :** Record a signal of 400 Hz, 0VU on a Hitachi UD-ER tape. Playback the tape and adjust RT2L, R for a playback output of 0VU  $\pm 0.5$  VU. Next, record 1.25 kHz and 12.5 kHz signals at the level of 0VU -20 dB. Playback the tape and adjust RT4L, R for an output difference within  $\pm 1$  dB.

**6. Dolby NR adjustment**

**Setting :** Recording mode

**Connection :**

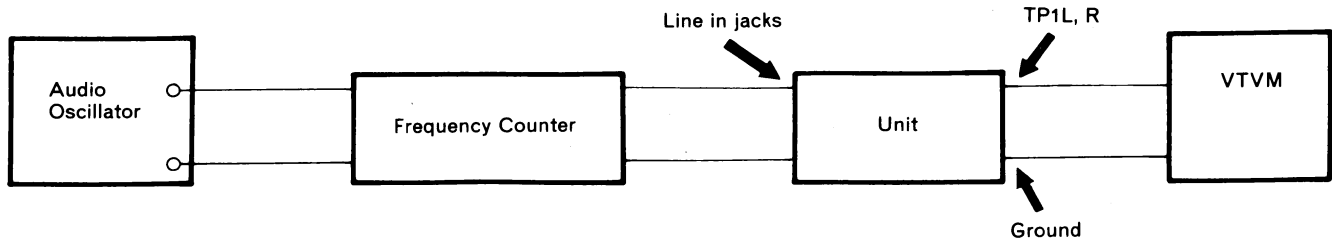

**Adjustment :** Set the record mode. Feed in a 5 kHz signal to the Line in jacks and adjust the input so that the voltage of TP1L, R becomes  $-30.4 \text{ dBm} \pm 0.1 \text{ dB}$ . Next, put the Dolby NR switch ON and adjust RT5 so that the voltage of TP1L, R becomes  $-22.4 \text{ dBm} \pm 0.1 \text{ dB}$ .

**ADJUSTMENT PARTS LOCATION**

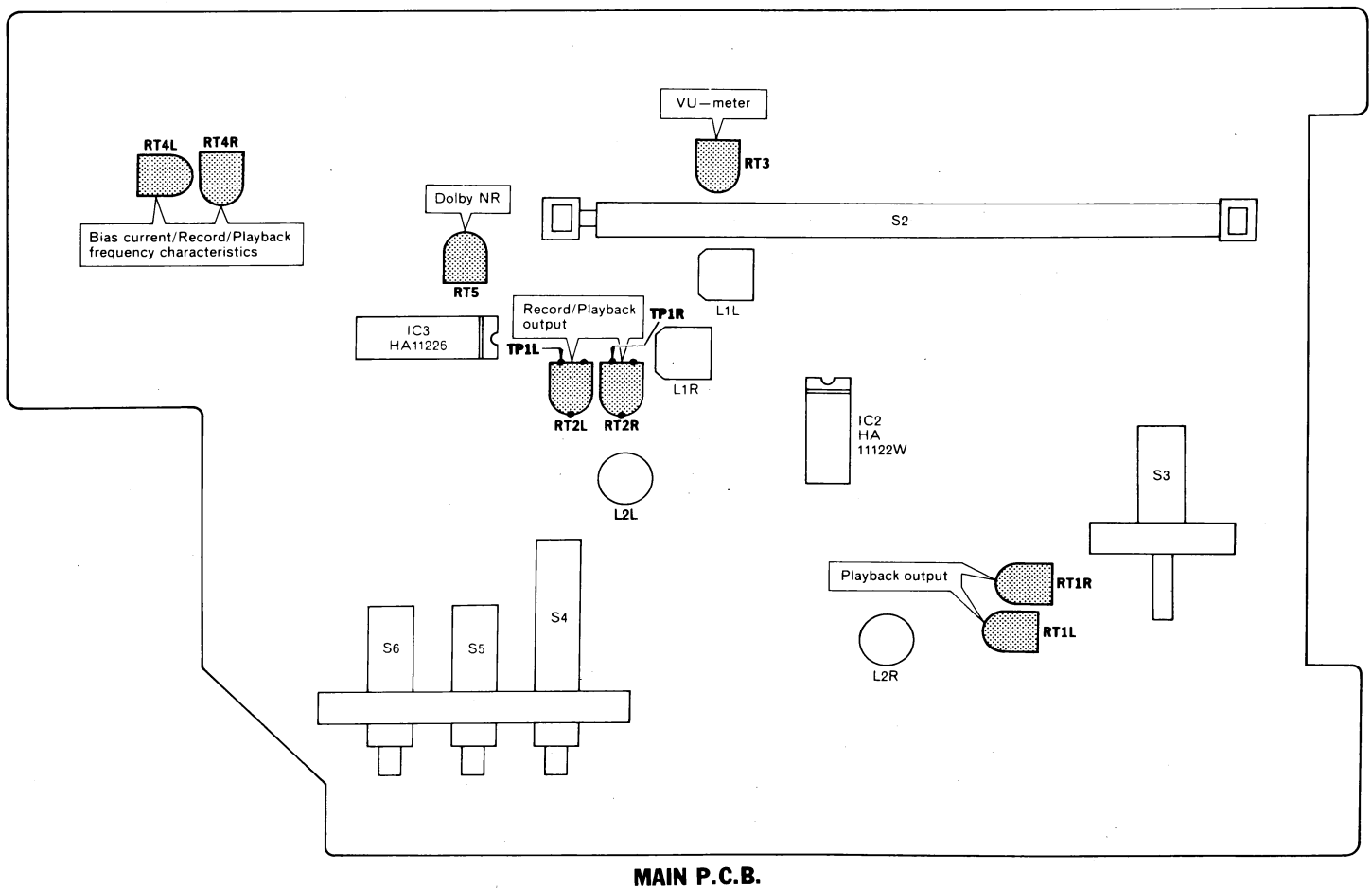

## REPLACEMENT PARTS LIST

### Inspection of mechanism

	Check item	Reference value	Remarks
1.	Pressure of pressure roller	350gr±50gr	Note 1
2.	Torque	Take-up	35 to 60gr-cm Measure in playback mode
		FF	70 to 120gr-cm Measure in FF mode
		Rewind	70 to 120gr-cm Measure in REW mode
3.	Back-tension	Take-up side	Less than 6gr-cm Values when installing the counter
		Supply side	1 to 3gr-cm
4.	Flywheel thrust gap	0.05 to 0.5mm	
5.	Pressure of take-up roller	120 to 180gr	Note 2
6.	Brake torque	more than 15gr-cm	

#### Note 1. Pressure of pressure roller

Set this unit in the playback mode and press the pressure roller in the direction of the arrow using a fan type tension gauge, and measure the pressure when the pressure roller is released from the capstan.

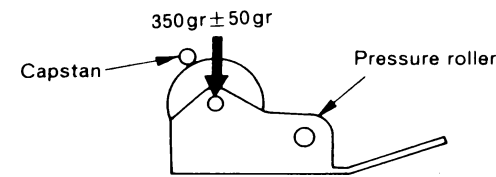

#### Note 2. Pressure of take-up roller

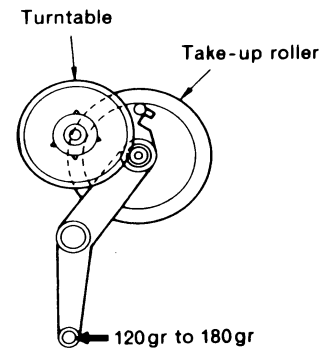

### LUBRICATION

Lubricate one or two drops of machine oil to rotating point or lubricate grease to sliding point. Lubricate the respective parts listed below once every 1000 hours or once a year under normal conditions of use. Avoid oiling them excessively, or rotation may become irregular because of oil splashes.

Lubrication	
Motor shaft bearing	Oil
Capstan shaft bearing	
Pressure roller bearing	

SYMBOL-NO	P-NO	DESCRIPTION	SYMBOL-NO	P-NO	DESCRIPTION
CAPACITORS					
C 1LR	0209022	CERAMIC DISC (RESISTOR SHAPE) 0.002 2MF±30%	Q 3	5321212	TRANSISTOR SILICON 2SD468B 190MHZ 0.9W
C 2LR	0209004	CERAMIC DISC (RESISTOR SHAPE) 330PF ±10%	Q 4	5320593	TRANSISTOR SILICON 2SA673C 80M (FOR BS, FS, AU, W)
C 4LR	0209009	CERAMIC DISC (RESISTOR SHAPE) 820PF ±10%	ZD 1	5330531	ZENER DIODE SILICON HZ-12A 10MHZ 40 0MW
C 9LR	0209006	CERAMIC DISC (RESISTOR SHAPE) 470PF ±10%	ZD 2	5330711	ZENER DIODE HZ48C
C15LR	0209008	CERAMIC DISC (RESISTOR SHAPE) 680PF ±10% (FOR U, C)	ZD 3	5330841	ZENER DIODE R05.1E-B
C15LR	0209010	CERAMIC DISC (RESISTOR SHAPE) 1000PF ±10% (FOR BS, FS, AU, W)	TRANSFORMERS		
C16LR	0209022	CERAMIC DISC (RESISTOR SHAPE) 0.002 2MF±30%	△ PT	5211931	POWER 12VA,400G (FOR W)
C32LR	0209002	CERAMIC DISC (RESISTOR SHAPE) 220PF ±10%	△ PT	5212495	POWER (FOR U, C)
C41	0209024	CERAMIC DISC (RESISTOR SHAPE) 4700PF ±30%	△ PT	5212493	POWER (FOR FS)
C42	0209010	CERAMIC DISC (RESISTOR SHAPE) 1000PF ±10%	△ PT	5212494	POWER (FOR BS)
C47	0209010	CERAMIC DISC (RESISTOR SHAPE) 1000PF ±10%	△ PT	5211932	POWER (FOR AU)
C49LR	0209010	CERAMIC DISC (RESISTOR SHAPE) 1000PF ±10%	COILS		
C52LR	0209009	CERAMIC DISC (RESISTOR SHAPE) 820PF ±10% (FOR BS, FS, AU, W)	L 1LR	5161665	DOLBY FILTER
C53LR	0209004	CERAMIC DISC (RESISTOR SHAPE) 330PF ±10%	L 2LR	5150571	CHOKO 33MH
RESISTORS					
RT 1LR	0151808	SEMI VARIABLE 10K OHM RS8B	L 3LR	5120562	TRAP
RT 2LR	0151808	SEMI VARIABLE 10K OHM RS8B	L 4	5260369	BIAS OSCILLATOR
RT 3	0151806	SEMI VARIABLE 1K OHM B	MISCELLANEOUS		
RT 4LR	0151819	VARIABLE 250K OHM	△	5658062	LED SOCKET
RT 5	0151808	SEMI VARIABLE 10K OHM RS8B	△	5746157	POWER CORD (FOR W)
RV 1LR	5000662	VARIABLE 20K OHM (A)	△	5746158	POWER CORD (FOR FS)
SEMI-CONDUCTORS					
D 1LR	5330572	DIODE SILICON 1S2473HC 100M	△	5746342	POWER CORD (FOR BS)
D 2LR	5330721	DIODE GERMANIUM 1N34A 10MHZ 50MW	△	5746442	POWER CORD (FOR U, C)
D 3LR	5330721	DIODE GERMANIUM 1N34A 10MHZ 50MW	△	5746571	POWER CORD (FOR AU)
D 4LR	5330721	DIODE GERMANIUM 1N34A 10MHZ 50MW	F 1	5720173	FUSE 500MA (FOR BS, FS, AU, W)
D 5	5331422	DIODE SM-1A-02	△ F 3	0591100	FUSE 200MA (FOR W)
D 6	5330571	DIODE 1S2473VE (FOR, BS, FS, AU, W)	△ F 4	5720105	FUSE 0.15A (FOR W)
D 7	5330572	DIODE SILICON 1S2473HC 100M (FOR, BS, FS, AU, W)	J 1LR	5679402	MIC JACK ASSEMBLY
D 8	5330572	DIODE SILICON 1S2473HC 100M (FOR, BS, FS, AU, W)	J 2	5679402	HEADPHONE JACK ASSEMBLY
D11	5331422	DIODE SM-1A-02	J 3LR	5676261	PIN JACK ASSEMBLY
D12	5330574	DIODE 1S2473	J 4LR	5676261	PIN JACK ASSEMBLY
IC 1	5350712	IC BA328	J 5	5651141	5P DIN SOCKET (FOR BS, FS, AU, W)
IC 2	5350462	IC HA11122W	LM	5554783	LEVEL METER
IC 3	5350561	IC HA 11226	RL1	5641141	REED RELAY (FOR BS, FS, AU, W)
LED1	5380271	LED GL-9PR2	△ S 1	5634162	PUSH SWITCH (POWER) (FOR W, AU)
Q 1LR	5322622	TRANSISTOR 2SC2320F	△ S 1	5637038	PUSH SWITCH (POWER)
Q 2	5322651	TRANSISTOR 2SD667C	S 2	5623511	SLIDE SWITCH (REC/PLAY)
FOR ACCESSORIES					
				7740321	HEAD CLEANING STICK
				5894163	PATCH CORD
				5662021	SOCKET ADAPTER (FOR W)

SCHEMATIC DIAGRAM

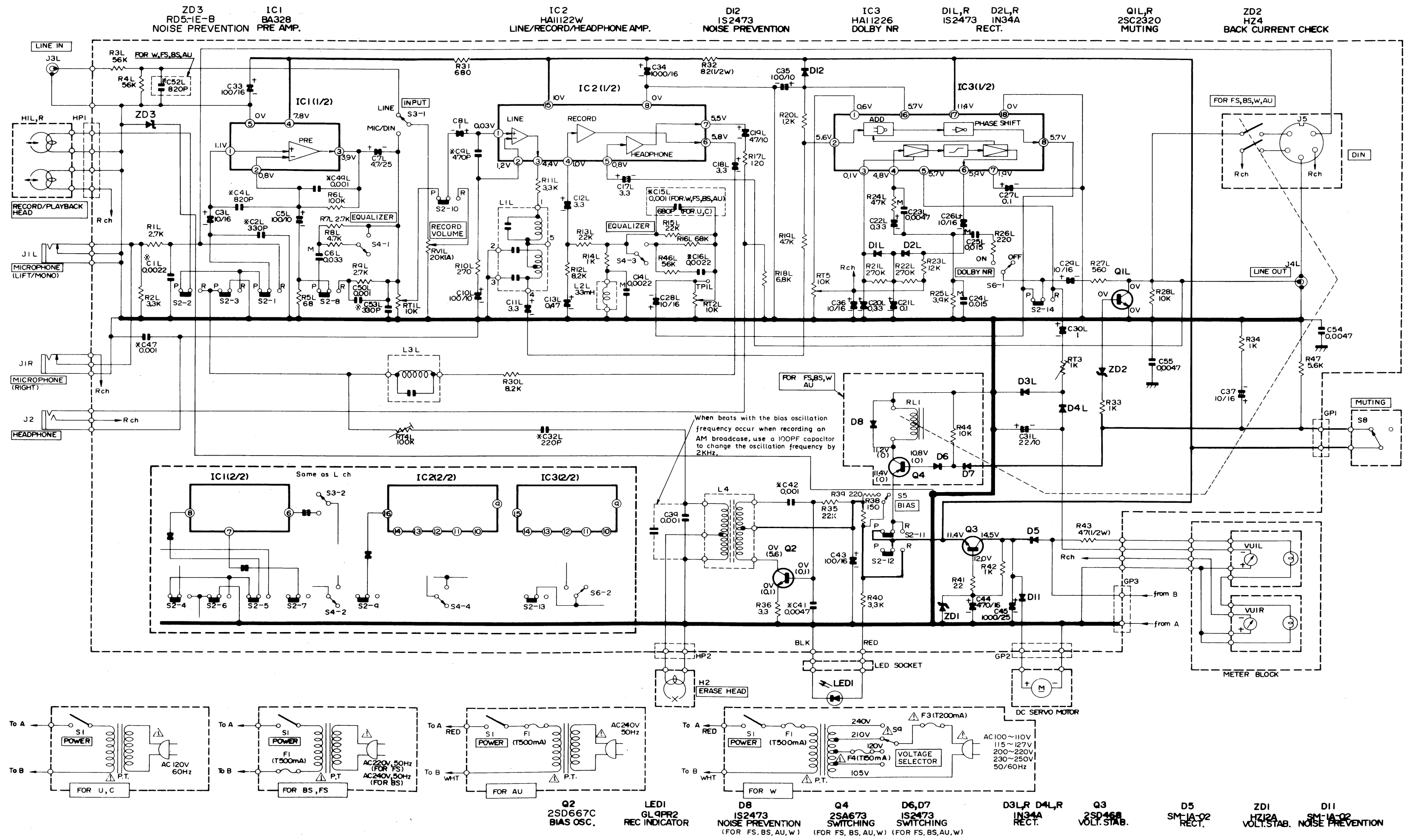

- Q2  
2SD667C  
BIAS OSC.
- LED1  
GL9FR2  
REC INDICATOR
- D8  
IS2473  
NOISE PREVENTION  
(FOR FS, BS, AU, W)
- Q4  
2SA673  
SWITCHING  
(FOR FS, BS, AU, W)
- D6, D7  
IS2473  
SWITCHING  
(FOR FS, BS, AU, W)
- D3L, R  
D4L, R  
IN34A  
RECT.
- Q3  
2SD468  
VOLT. STAB.
- D5  
SM-1A-02  
RECT.
- ZD1  
HZ12A  
VOLT. STAB.
- D11  
SM-1A-02  
NOISE PREVENTION



**CIRCUIT BOARD DIAGRAM**

■ : Ground

■ : Signal, +B

■ : Component side pattern

**Note**

1. Voltage measured at base of chassis with minimum volume control and no signal.
2. Nomenclature of Resistors and Capacitors.

Circuit No.		Value	No indicated	Ω(Ohm)
R101 150 RS-1-K	Tolerance	No indicated	±5%	
		K	±10%	
Wattage	No indicated	¼W		
	Sort	No indicated	Carbon film	
Sort	RC	Composition		
	RW	Wire wound		
	RS	Oxide metal film		
	RN	Fixed metal film		

Circuit No.		Value	No indicated	μF
C101 0.001-M	Tolerance	No indicated	±10%	
		J	±5%	
Sort	Capacitor Type	C	±20%	
		Z	+80% -20%	
		D	±0.5pF	
		C	±0.25pF	
Voltage	No indicated		50WV	

3. Be sure to make your orders of resistors and capacitors with value, voltage, tolerance and sort.
4. When replacing capacitors marked with \*, use specified ones stated on parts list since required temperature characteristics.

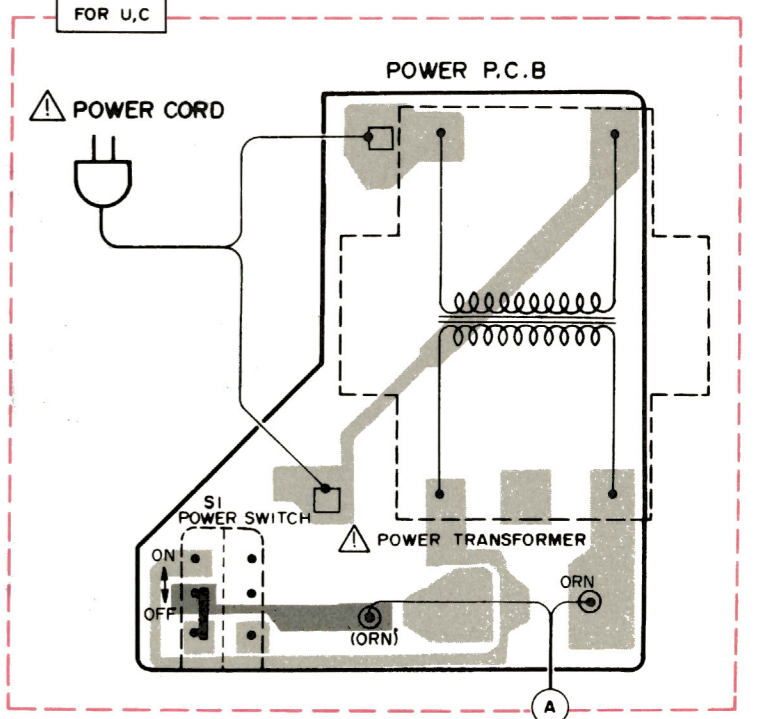
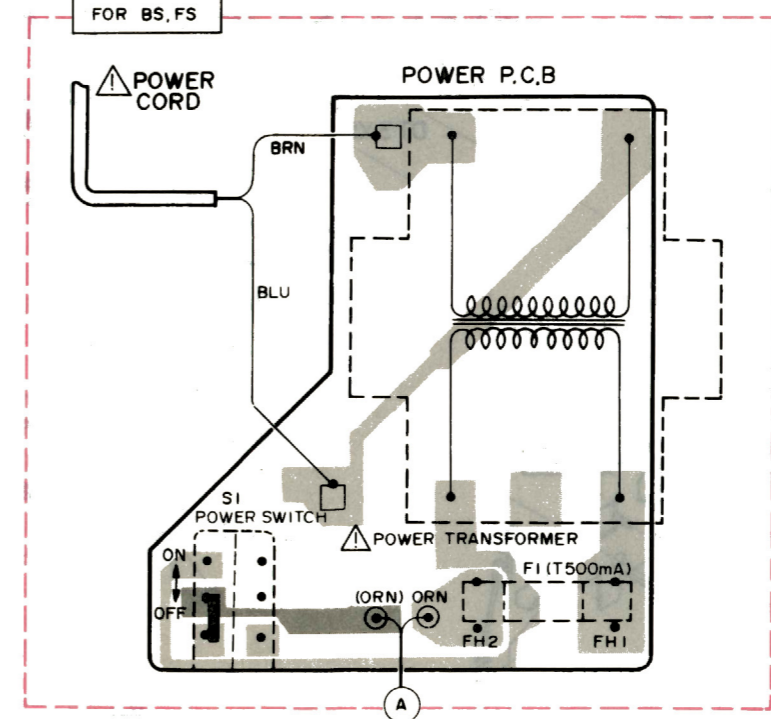
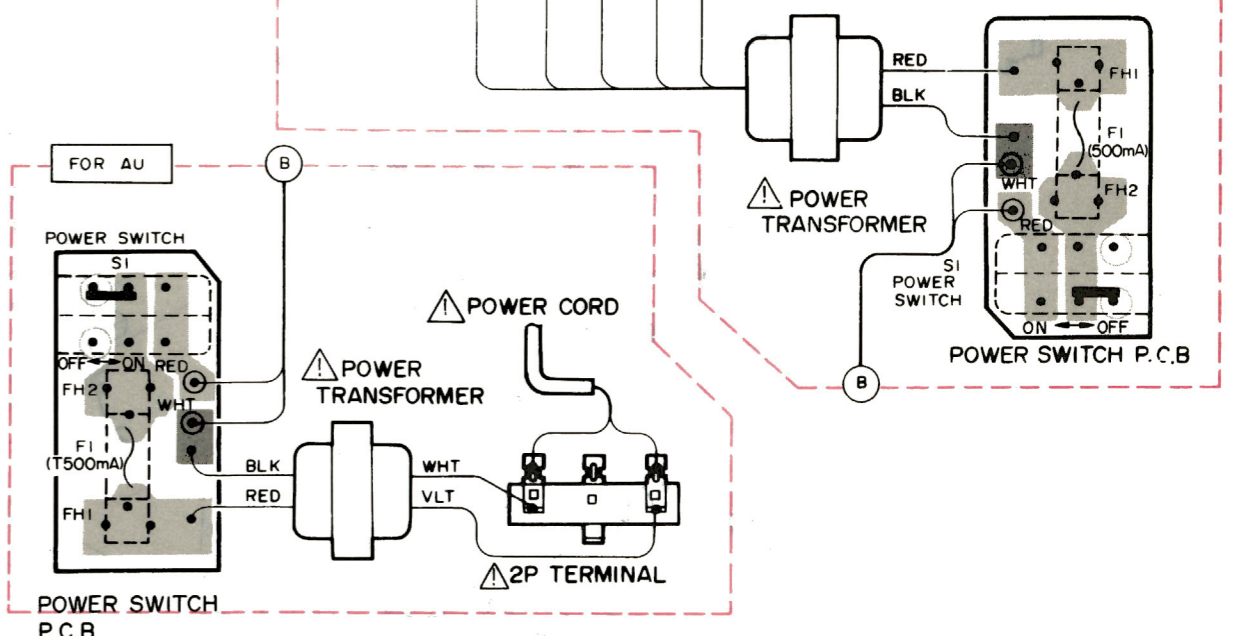
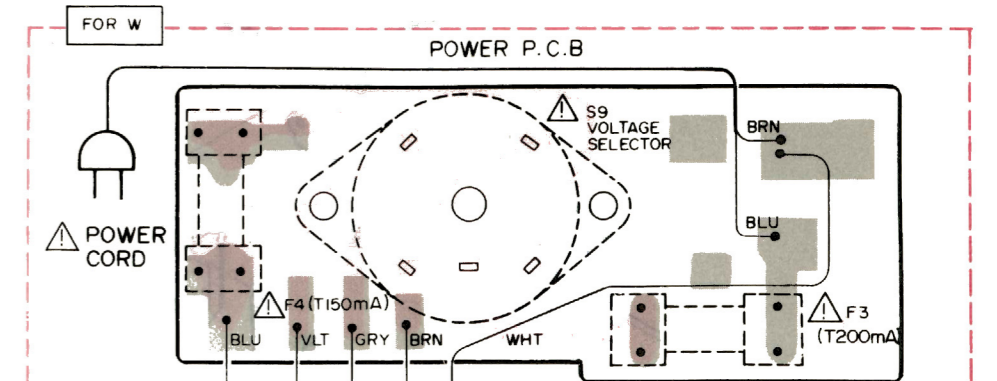
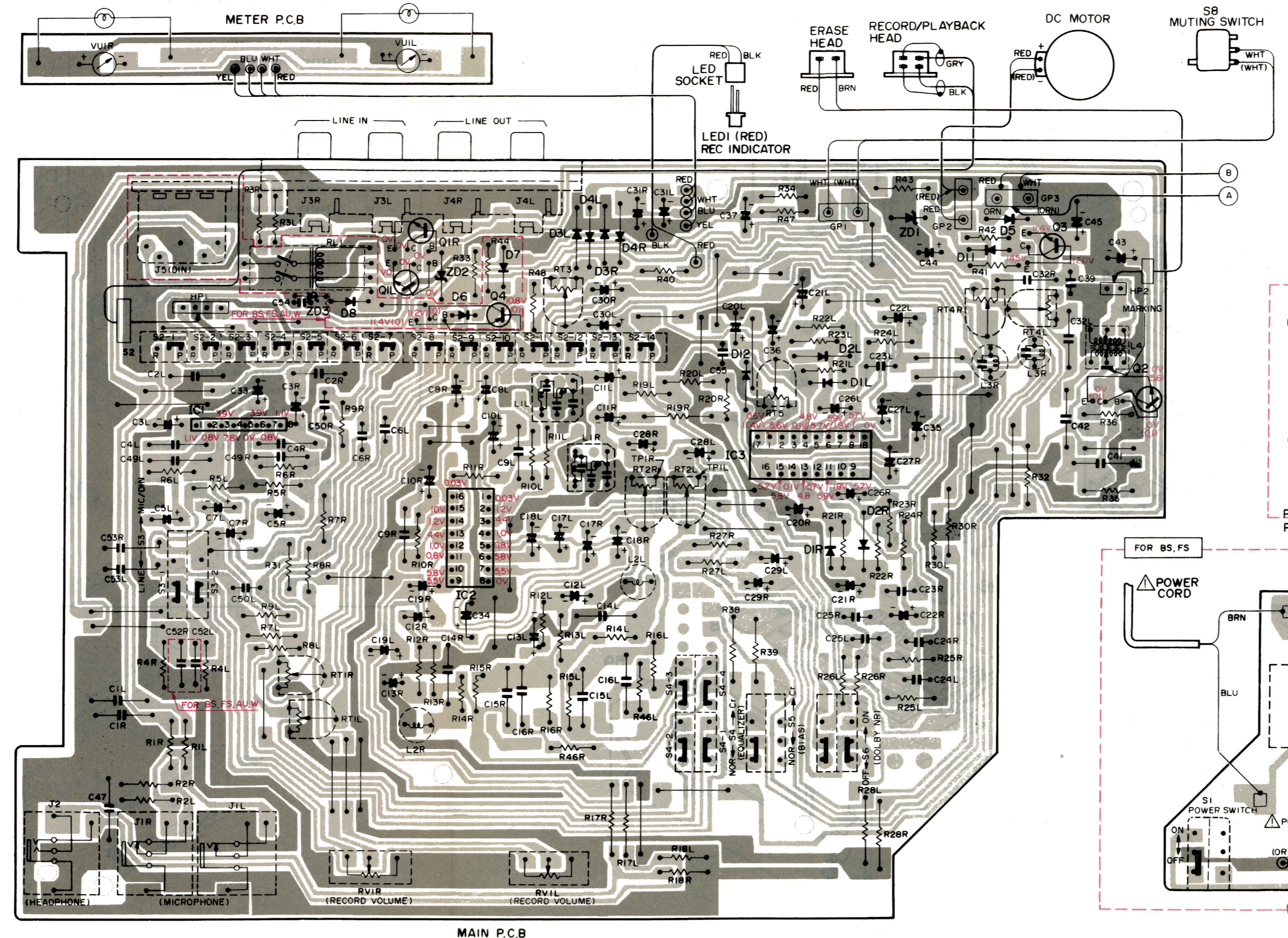
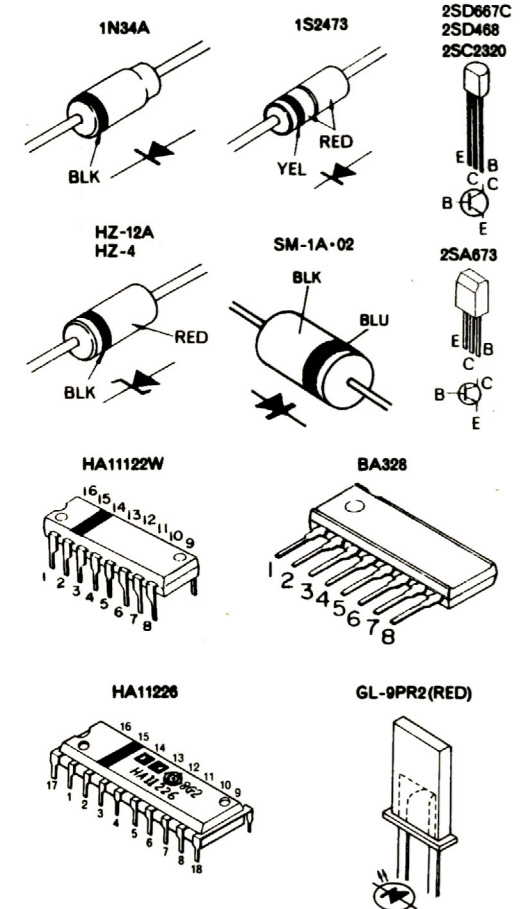



EXPLODED VIEW

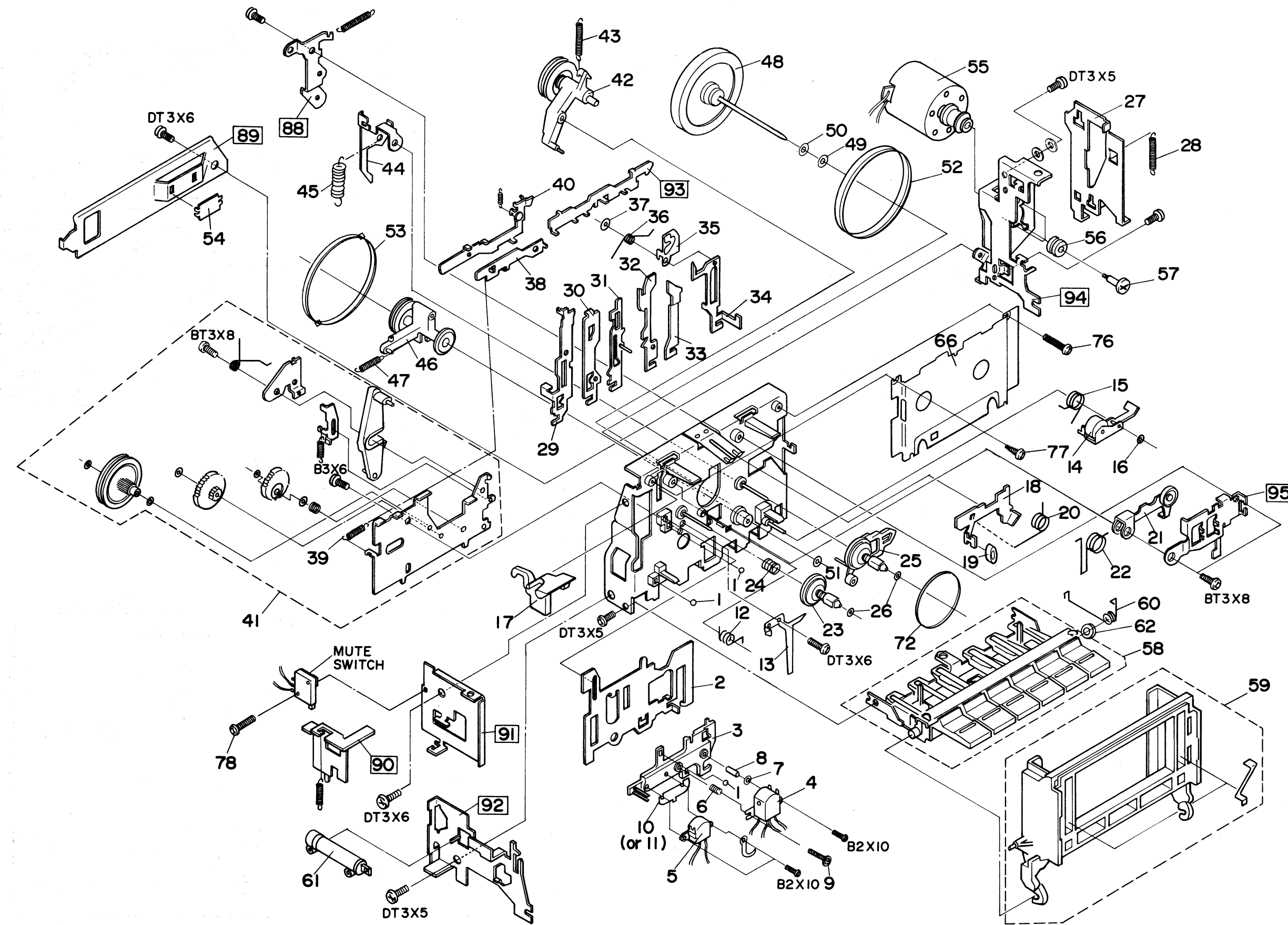

Note: Components marked with Number in this drawing are not specified replacement parts.

REPLACEMENT PARTS LIST

SYMBOL-NO	P-NO	DESCRIPTION	SYMBOL-NO	P-NO	DESCRIPTION
FOR CASSETTE CHASSIS ASSEMBLY (A)					
1	0948492	BALL - 2MMD	32	7315424	F.F SLIDER
2	7321163	HEAD PLATE	33	7315443	STOP SLIDER
3	6758872	HEAD BASE	34	7324431	PAUSE SLIDER ASSEMBLY
4	5444931	RECORD PLAYBACK HEAD	35	7315215	PAUSE LOCK PIECE
5	5445281	ERASE HEAD	36	6545711	SPRING
6	6321733	HEAD SPRING C	37	7786179	POLYESTER WASHER
7	7779921	WASHER	38	7324421	RECORD PREVENTION PLATE
8	7574844	COLLAR	39	6302821	SPRING FOR EJECT LEVER
9	7781001	SCREW	40	7324321	BRAKE FUNCTION SLIDER ASSEMBLY
10	7768181	HEAD SPACER	41	6413911	AUTO STOP BLOCK ASSEMBLY
11	7768182	SPACER	42	6413506	TAKE UP ARM ASSEMBLY
12	6545776	HEAD PLATE SPRING	43	6300291	SPRING
13	6532872	LEAF SPRING	44	7315083	BRAKE LEVER
14	6383621	PRESSURE ROLLER ARM ASSEMBLY	45	6324437	SPRING
15	6545766	SPRING FOR PRESSURE ROLLER ARM	46	6413512	REWIND ARM ASSEMBLY
16	7786219	POLYESTER WASHER	47	6322473	DOOR SPRING
17	6752873	RECORD PREVENTION ARM	48	6373603	FLYWHEEL ASSEMBLY
18	7315365	BRAKE PLATE	49	7778848	POLY SLIDER WASHER
19	6586004	RUBBER FOR BRAKE	50	7772623	SPRING
20	6545692	BRAKE SPRING	51	7786623	POLY SLIDER WASHER
21	7315272	F.F ARM ASSEMBLY	52	6357403	FLYWHEEL BELT
22	6545682	SPRING	53	6355171	BELT
23	6412504	TURNTABLE ASSEMBLY (SUPPLY)	54	6743884	THRUST SUPPORT
24	6304031	SPRING	55	5576531	MOTOR ASSEMBLY
25	6413993	TURNTABLE ASSEMBLY (TAKE UP)	56	6576084	RUBBER PLATE
26	7786115	POLYESTER WASHER	57	7539002	SCREW FOR MOTOR MOUNTING
27	7324312	EJECT SLIDER	58	7328874	BUTTON ASSEMBLY
28	6300842	SPRING	59	6092655	CASSETTE HOLDER ASSEMBLY
29	7315103	RECORD SLIDER	60	6545933	SPRING
30	7315414	REWIND SLIDER	61	6754582	PISTON
31	7324482	PLAY SLIDER ASSEMBLY	62	7786628	POLY SLIDER WASHER

REPLACEMENT PARTS LIST

SYMBOL-NO	P-NO	DESCRIPTION	SYMBOL-NO	P-NO	DESCRIPTION
FOR CASSETTE CHASSIS ASSEMBLY (B)					
△	63	0043793 BUSHING (FOR U, C, FS, AU)	77	7780915 BIND TAPPING SCREW-2MMX5MM	
△		6711351 BUSHING (FOR BS)	78	0671310 DT SCREW-2.6MMX10MM	
△		6794041 BUSHING (FOR W)	MISCELLANEOUS		
	64	7320393 RECORD LEVER ASSEMBLY	79	6053061 PUSH BUTTON ASSEMBLY (POWER)	
	65	7324751 EARTH HOLDER ASSEMBLY	80	6053104 PUSH BUTTON DOLBY NR, BIAS, EQUALIZER (FOR U)	
	66	7325211 CASSETTE METAL		6053102 PUSH BUTTON DOLBY NR, BIAS, EQUALIZER (FOR C, FS, BS, AU, W)	
	67	6223631 FRONT PANEL ASSEMBLY (FOR U, C, BS, AU, W)	81	6052492 PUSH BUTTON ASSEMBLY (INPUT) (FOR C, FS, BS, AU, W)	
		6223632 FRONT PANEL ASSEMBLY (FOR FS)		6052495 PUSH BUTTON ASSEMBLY (INPUT) (FOR U)	
	68	6257874 EJECT BUTTON (FOR U)	82	6287871 KNOB ASSEMBLY (RECORD LEVEL) (FOR C, FS, BS, AU, W)	
		6257872 EJECT BUTTON (FOR C, FS, BS, AU, W)		6288081 KNOB (RECORD LEVEL) (FOR U)	
	69	6304186 SPRING	83	6042301 BOTTOM COVER	
	70	6759051 EJECT ROD	84	6042321 UPPER COVER (FOR FS, BS, AU, W)	
	71	5559263 COUNTER		6042322 UPPER COVER (FOR U, C)	
	72	6355062 COUNTER BELT	85	6092682 CASSETTE DOOR	
	73	7781131 B TIGHTING SCREW-3MMX12MM	86	6182173 HEAD COVER	
	74	7781582 FALT SCREW-3MMX10MM (BLACK)	87	7781731 BT BIND SCREW-4MMX10MM (FOR FS, BS, AU, W)	
	75	8699410 BT BIND HEAD SCREW-3MMX10MM (BLACK)		8699610 BT BIND SCREW-4MMX10MM (FOR U, C)	
	76	0678312 DT SCREW-2.6MMX12MM (BLACK)			

EXPLODED VIEW

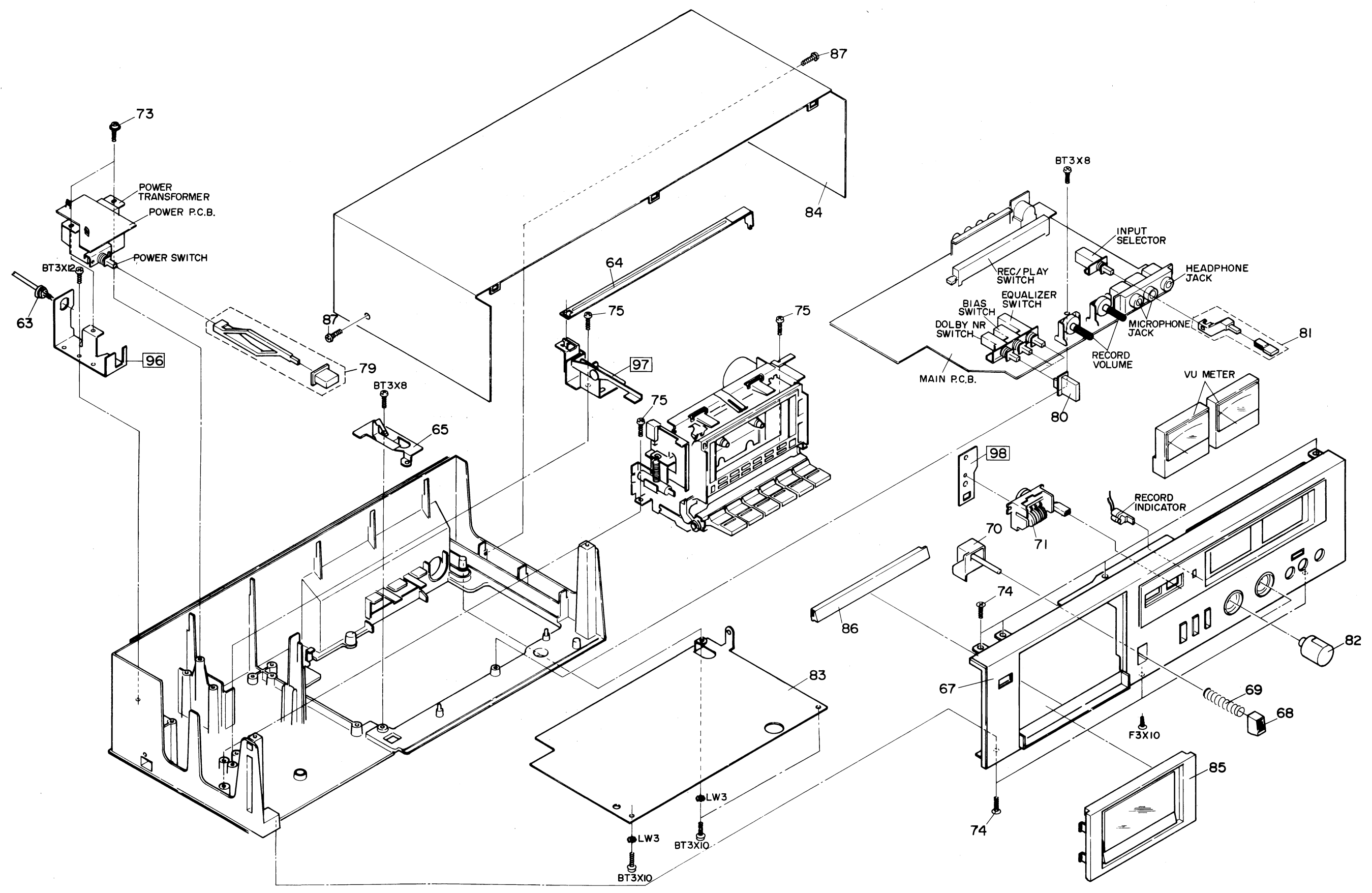

Type of head				
P	Pan head screw	BT	Binding head tapping screw	
F	Flat countersunk head screw	BL	Bolt	
B	Binding head screw	W	Washer	
T	Round head tapping screw	E	"E" ring	
Length (L mm)				
Diameter (D mm)				

When ordering hardware excluding stated on these lists, be sure to make your orders with type and size.

Note: Components marked with Number in this drawing are not specified replacement parts.

BLOCK DIAGRAM

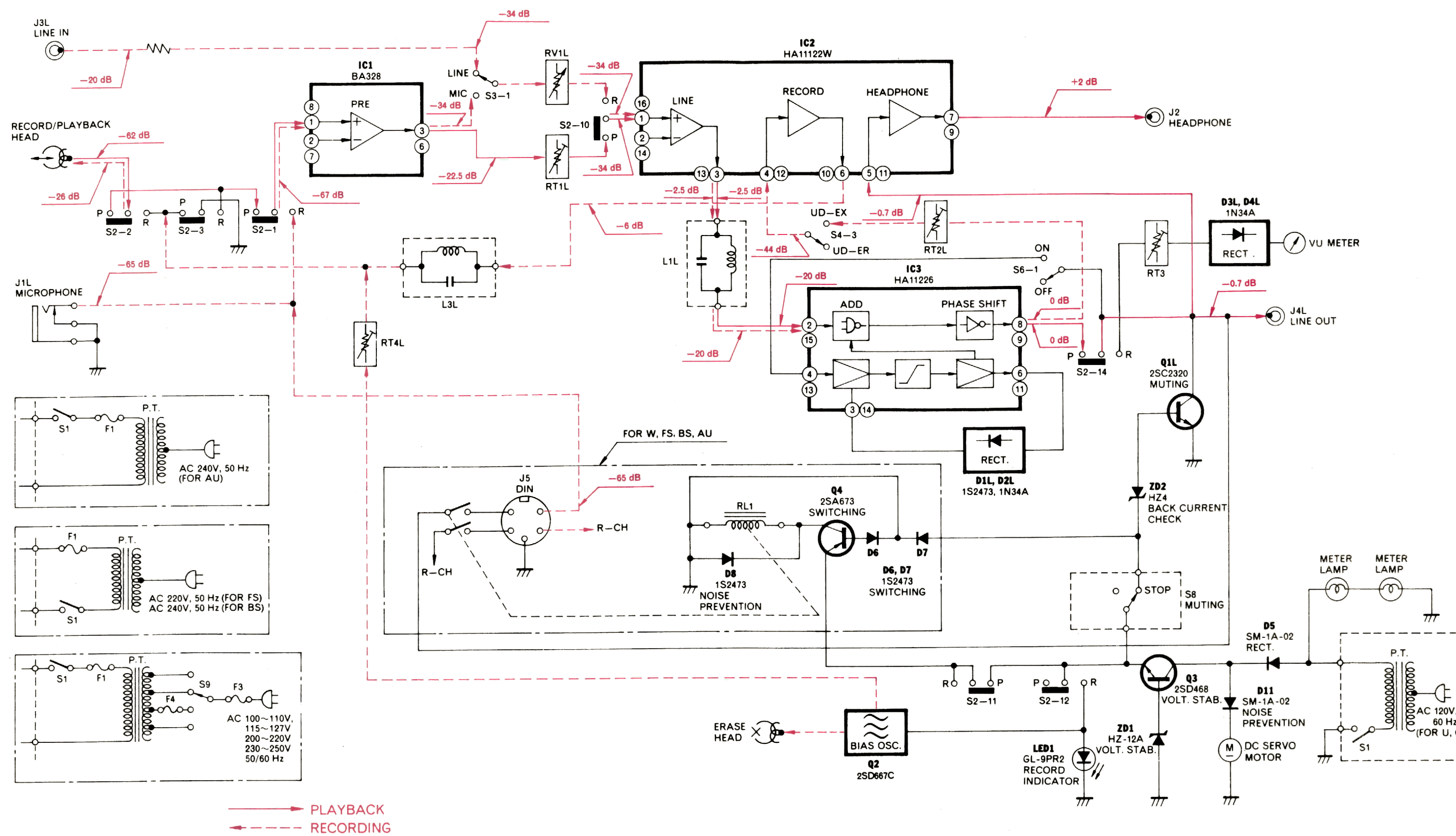

**HITACHI SALES CORPORATION OF AMERICA**  
 Eastern Regional Office  
 1200 Wall Street West, Lyndhurst, New Jersey 07071  
 Tel. 201-935-8980  
 Mid-Western Regional Office  
 1400 Morse Ave., Elk Grove Village, Ill. 60007  
 Tel. 312-593-1550  
 Southern Regional Office  
 510 Plaza Drive College Park, Georgia 30349  
 Tel. 404-763-0360  
 Western Regional Office  
 401 West Artesia Boulevard, Compton, California 90220  
 Tel. 213-537-8383  
**HITACHI SALES CORPORATION OF HAWAII, INC**  
 743-G Waiakamilo Rd., Honolulu, Hawaii 96817  
 Tel. 808-841-0431

**HITACHI SALES CORP. OF CANADA Ltd.**  
 3300 Trans Canada Highway Pointe Claire, Quebec, H9R1B1, Canada  
 Tel. 514-697-9150

**HITACHI SALES EUROPA GmbH**  
 2 Hamburg 54, Kleine Bahnstraße 8, West Germany  
 Tel. 850 60 71-75

**HITACHI SALES (U.K.) Ltd.**  
 Hitachi House, Station Road, Hayes, Middlesex UB3 4DR, England  
 Tel. 01-848-8787 (Service Centre : 01-848-3551)

**HITACHI SALES SCANDINAVIA AB**  
 Rissneleden 8, Sundbyberg, Box 7138, S-172-07 Sundbyberg 7, Sweden  
 Tel. 08-98 52 80

**HITACHI SALES NORWAY A/S**  
 Oerebekk 1620 Gressvik P.O. Box 46 N-1601 Fredrikstad, Norway  
 Tel. 032-28050

**SUOMEN HITACHI OY**  
 Box 151, SF-15100 Lahti 10, Finland  
 Tel. Lahti 44 241

**HITACHI SALES A/S**  
 Kuldysen 13, DK-2630 Taastrup, Denmark  
 Tel. 02-999200

**HITACHI SALES A.G.**  
 5600 Lenzburg, Switzerland  
 Tel. 064-513621

**HITACHI-FRANCE (Radio-Télévision Electro-Ménager) S.A.**  
 9, Boulevard Ney 75018, Paris, France  
 Tel. 201-25-00

**HITACHI SALES WARENHANDELS GMBH**  
 A-1180/Wien, Kreuzgasse 27  
 Tel. (0043222) 439367/8

**HITACHI SALES AUSTRALIA Pty Ltd.**  
 153 Keys Road, Moorabbin, Victoria 3189 Australia  
 Tel. 95-8722

**HITACHI Ltd. TOKYO JAPAN**  
 Head Office : 5-1, 1-chome, Marunouchi, Chiyoda-ku, Tokyo  
 Tel. Tokyo (212) 1111 (80 lines)  
 Cable Address : "HITACHY" TOKYO  
 Codes : All Codes Used